



Parker Balston® Cabinet Dryer

Installation, Operation, and Maintenance Manual

aerospace
climate control
electromechanical
filtration
fluid & gas handling
hydraulics
pneumatics
process control
sealing & shielding

Parker Balston® Cabinet Dryer Models CD0005, CD0010, CD0030

Installation, Operation, and Maintenance Manual

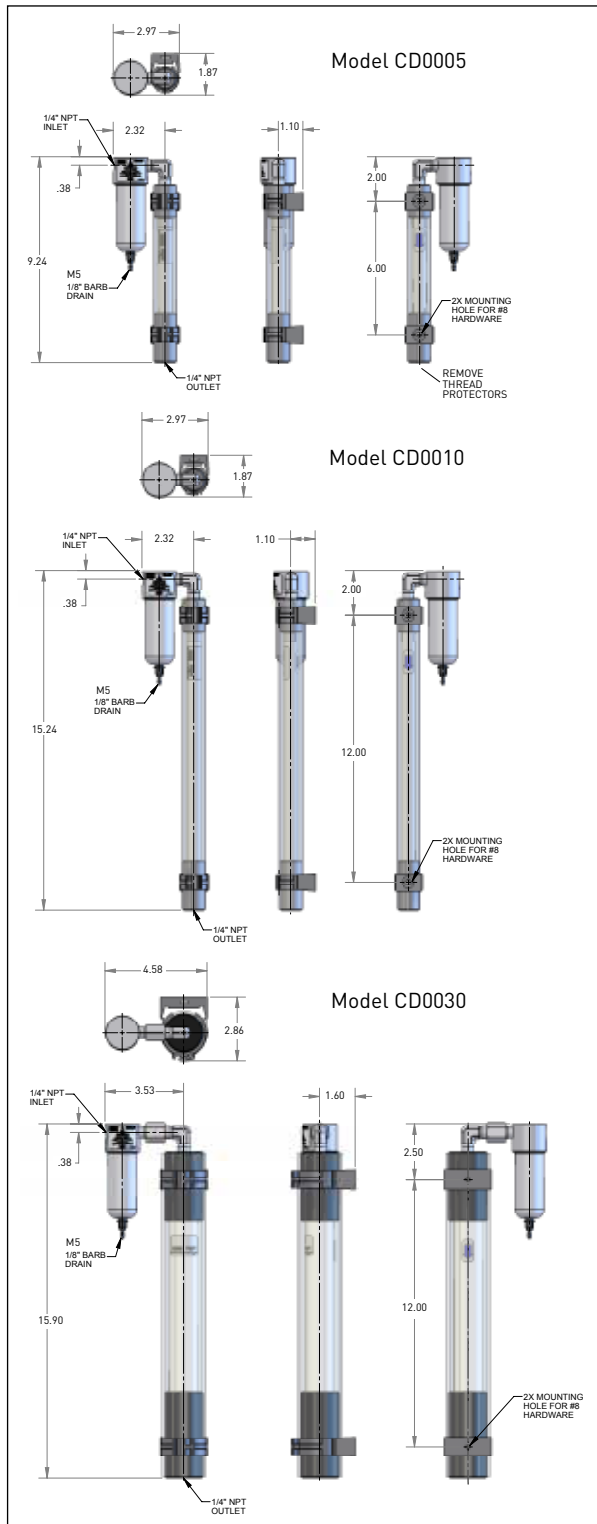

Figure 1: Dimensions

These instructions must be thoroughly read and understood before installing and operating this product. If you have any questions or concerns, please call the Technical Services Department at 800-343-4048, 8AM to 5PM Eastern Time or email at balstontechsupport@parker.com (North America only). For other locations, please contact your local representative.

General Description

The Parker Balston Cabinet Dryer (see Figure 1) provides clean, dry compressed air from an existing compressed air supply through the use of state-of-the-art membrane technology. The dryers come preset to deliver dry air with a dewpoint of less than 0°F (-18°C). The Cabinet Dryer will effectively reduce the humidity inside electrical cabinets to less than 10% relative humidity without the need for an electrical supply or messy desiccants to change out.

Each dryer is equipped with a high efficiency coalescing prefilter to remove oil, water, and particulate contamination to 0.01 micron. The dryer is made from corrosion resistant stainless steel, FEP, and PVC to withstand the harshest chemicals. Included in the box are two mounting brackets, a strain relief bushing, warranty, this installation, operation and maintenance manual, and the cabinet dryer.

Installation and Operation

All installation, operation, and maintenance procedures for the Parker Balston Cabinet Dryers should be performed by suitable personnel using reasonable care.



Warning: Use PTFE tape on all threaded components. Use of pipe sealants other than PTFE tape may damage the membrane and void the warranty.

Mount the compressed air dryer to a vertical surface near the cabinet. All mounting hardware should be adequately sized to support the weight of the dryer in its mounted position. First mount the included click brackets 8" or 12" apart, depending on the model (see figures 1 and 2). Then insert the dryer and push toward the vertical surface until the brackets "click".

Outlet Connection



In order to purge the cabinet, connect a 1/4" NPT tube fitting to the outlet of the membrane module with a snug fit. **Be careful not to over-torque the fitting or you may damage the module.** Connect a line to the outlet fitting and run it through to the inside of the cabinet. A NEMA type 4x compliant strain relief bushing is included. Use the bushing to deliver the air from the dryer to the interior of the cabinet. The strain relief bushing must be installed per the manufacturer's instructions in order to maintain the NEMA 4x rating for the enclosure. Position the tubing along the side or bottom of the cabinet. Do not direct the air at electrical components.

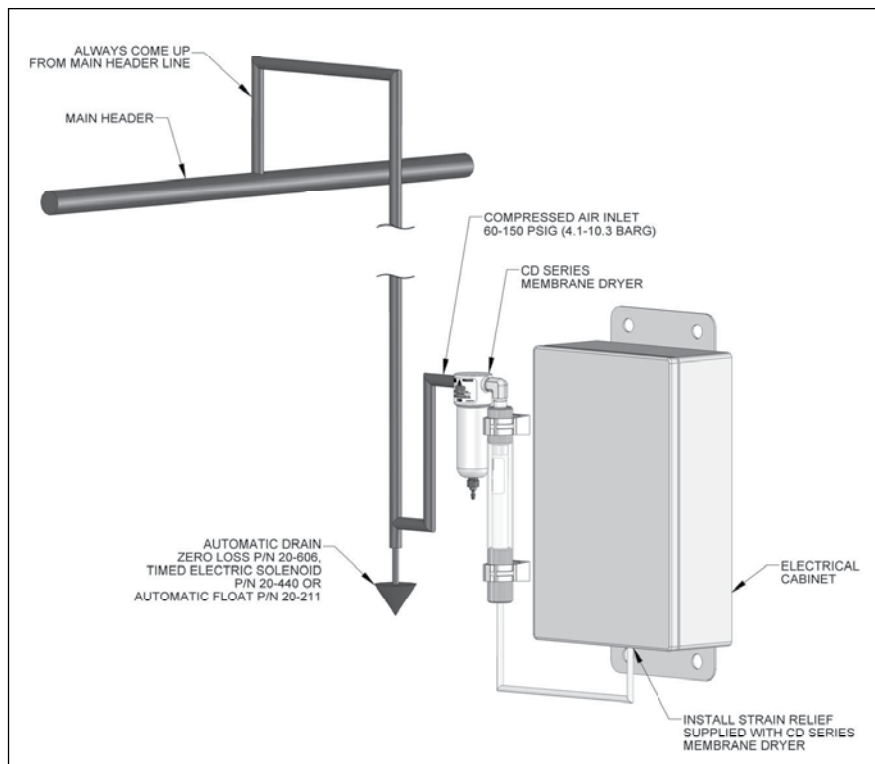

Figure 2: Recommended Installation

Compressed Air Supply

The compressed air supply pressure should be between 60 psig and 150 psig (4.1 barg and 10.3 barg) for proper operation of the dryer. Operating Temperature should be between 3°F and 120°F. Optimal drying occurs at 100 psi or higher. **Do not exceed recommended inlet air temperatures or pressures, or the performance and life of the module may be adversely affected and the warranty will be void.**



If the compressed air supply contains excess water and/or oil, install an additional coalescing prefilter (Grade DX) upstream from the cabinet dryer.

The cabinet dryers maintain a constant "sweep" flow to carry water vapor laden air away from the membrane module. This sweep flow may be audible and is normal.

Automatic Drain

The high efficiency coalescing prefilter, integral to the cabinet dryer, is equipped with an automatic drain. The coalescing filter must be mounted vertically for proper drain operation. The drain will pass small quantities of water and compressor oil, the drain is fitted with a 1/8" barb for connecting a drain tube.

Operation

The Balston Cabinet Dryer operates continuously with a constant bleed of sub-zero dewpoint dry air. In some instances, for example if the cabinet door is accidentally left ajar, water may accumulate at the bottom of the cabinet. This water should not affect the operation of sensitive electrical components. The cabinet dryer produces a continuous purge of dry air that blankets the components and isolates them from the moisture at the bottom of the cabinet.

If you have any questions, contact the Technical Services Department at 1-800-343-4048, 8AM to 5PM Eastern Time (North America only) or email at basltontechsupport@parker.com. For other locations, please contact your local representative.

Maintenance

Depressurize the dryer prior to performing any service.

The only maintenance required by the cabinet dryer is the annual replacement of the prefilter cartridge (see Figure 1).¹

The filter cartridge in the prefilter assembly is removed by loosening the bowl from the filter head or turning the bowl counter-clockwise. Lower the filter bowl away from the filter head and unscrew the element retainer from the base of the cartridge. Insert the new filter cartridge and reassemble the housing in reverse order. The time required to change the prefilter cartridge on the cabinet dryer is approximately 5 minutes.

The Cabinet Air Dryer may be cleaned by wiping down with a damp cloth.

Ordering Information

Spare Parts	CD0005	CD0010	CD0030
Prefilter Replacement Box of 10	070-063-BX	070-063-BX	070-063-BX
Strain Relief Bushing w/hut and O-ring	A01-0367	A01-0367	A01-0367
Replacement Clamp	A07-0016	A07-0016	A07-0017
Seal Set	A05-0096	A05-0096	A05-0096
Replacement Module Assembly	D03-0074	D03-0075	D03-0076
Replacement Auto Drain for 6102N	C02-2392	C02-2392	C02-2392

Notes:

1 To ensure consistent product performance and reliability use only genuine Parker Balston replacement parts and filter cartridges. Heavily contaminated air may dictate more frequent filter replacements and additional prefiltration.

Remember To:

Complete and mail or fax in your Warranty Registration Card.

Serial Numbers

The Serial Number is located above the product label on the membrane module. For your own records, and in case service is required, please record the following:

DATE IN SERVICE _____ SERIAL NO. _____

WARRANTY (NORTH AMERICA ONLY)

(FOR INFORMATION CONTACT YOUR LOCAL REPRESENTATIVE)

Parker Hannifin guarantees to the original purchaser of this product, that if the product fails or is defective within 12 months from the date of purchase, when this product is operated and maintained according to the instructions provided with the product, then Parker guarantees, at Parker's option, to replace the product, repair the product, or refund the original price for the product. This warranty applies only to defects in material or workmanship and does not cover: ring and valve wear on compressors, routine maintenance recommended by the instructions provided with this product, or filter cartridges. Any modification of the product without written approval from Parker will result in voiding this warranty. Complete details of the warranty are available on request. This warranty applies to units purchased and operated in North America.

Explanation of Warning Symbols

Symbol



Description

Caution, refer to accompanying documents for explanation.

Parker Hannifin Corporation
 Filtration and Separation Division
 242 Neck Road
 Haverhill, MA 01835
 Tel: 978-858-0505 Fax: 978-556-7501
 www.parker.com/balston

Parker Hannifin (UK) Ltd.
 Industrial Division
 Suite 42, Kent House, Romney Place
 Maidstone, Kent ME15 6LH United Kingdom
 Tel: +44 (0)1622 772440 Fax: +44 (0)1622 772446
 TSGIndustrial.Enquiries@parker.com www.parker.com/pag



CELL: SMD